



SHOWER
POWER
BOOSTER

INLINE MICRO PUMP



Information Manual
www.showerpowerbooster.co.uk

Boosts water flow to any shower, tap & so much more!

01/07/2025



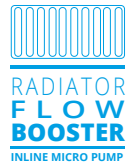

Front Page	1
Contents	2-3
Our Customers	4
Introduction	5
Potable Water Product Range	6
WrightChoice Water Product Range	7
WrightChoice Shower Heads	8
Affordable Heat Storage	9-11
Technical Specifications	12
Three Step Installation	13
Fitting Pumps In Tight Situations - A must read for some	14
Using Our 22-15mm 3 Piece Reducing Sets	15
Making a Compression Joint With No Leaks	16
Filters In Our ShowerPowerBoosters	16
28mm Pipe Solution	17
Negative Head And Manual Switching	18
Double Flow Or Triple Flow	19
Double Boosting Hot and Cold	20
SP2B & SP21s Wiring Diagrams	21
SP22s & Fitting Pumps Over 1 Metre Apart	22
Whole House Solution (Gravity Hot And Cold)	23
Protected Flow Solution (Gravity Hot and Cold)	23
Boosting Hot and Cold (Gravity Hot and Cold)	24
Boosting Kitchen Taps	24
Replacing An Existing Power Shower	25
Whole House Solution (Gravity Hot and Mains Cold)	26
Protected Flow Solution (Gravity Hot and Mains Cold)	26
Boosting Fortic And Close Coupled Tanks	27

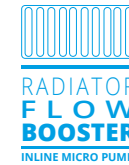

Low Water Mains Pressure	28
Electric Shower Boost Solutions	28
Combination Boiler Solutions (Whole House)	29
Combination Boiler Solutions (Protected Flow)	29
Unvented Mains Pressure Tank Solutions	30-31
Instant Hot Water At Showers And Taps	32
Pumps Fitted In Loft (Gravity Hot And Mains Cold)	33
Pumps Installed Under Bath - (Gravity Hot And Mains Cold)	34
Loft Conversions	34
Hot Water Cylinder On Ground Floor	35
Trevi Boost	36
Fault Finding, Diagnostics, And Solutions	37-40
Radiator Flow Boosters	41-42
V2 Radiator Booster	43
Flowflex	44-45
Innovative Products	46
Innovative Technologies	47
Back Cover - The Inventor	48

Register your interest in installing SPBs and affordable heat stores in your area.

We are currently recruiting plumbers for work in Norwich (see page 9)

- **Free to register**
E-mail alanderekwright@icloud.com
- **Free advertising**
Your contact details will be displayed on our website map - www.showerpowerbooster.co.uk/plumbers-forum
- **Free leads**
Customers will contact you directly





Our customers are experienced plumbers, capable DIYers and people who simply want to give it a go and use the advice in this manual to fit our pumps.

You may decide that you want to find a plumber or another DIYer in your area to fit the pumps for you and we advertise the services of such people on our website. Maybe recommend your own plumber?

The ShowerPowerBooster is truly unique and our customers can solve pressure problems in any and all plumbing systems (see contents pages for your application).



Rated the **number one pump** in the UK by our customers by scoring a full 5 stars overall on  **Trustpilot**

Over 1,500 Reviews



The Shower Power Booster (SP2B) is an award winning, innovative product, celebrated for its power versus size properties, winning Best Water Innovation by Imperial College London 2012.

WRAS approved and fully factory tested, the pump comes with a 2 year warranty which can be extended to 3 years.

Designed as a retro-fit booster, it uses a safe 12-volt brushless motor which is highly efficient, fully waterproof and has low friction long-life bearings.

It is highly efficient when delivering volumes of water of up to 6.5 litres per minute to a traditional shower head or tap and it can deliver up to 9 litres of blended water for rain showers and bath taps.

The SP2B does not restrict flow and it automatically deactivates itself in the event of high flow rates or in a power cut, so your original flow is fully restored.

The Shower Power Booster has been installed in thousands of homes across the UK and beyond since 2012 with excellent customer satisfaction.

It comes with a 30 day money back return period if bought through showerpowerbooster.co.uk We encourage customers to trial the product and guarantee a refund if you are not fully satisfied.

ShowerPowerBooster pumps have been manufactured under licence in the UK by Flowflex Components Ltd since 2013.

Shower Power Booster appeared on Dragons Den in 2013: Search on YouTube:

'Shower Power Booster Dragons Den'



SINGLE PUMPS

**SP2B
AUTOMATIC SHOWER POWER BOOSTER**



**SP1
MANUAL SHOWER POWER BOOSTER**



Both Automatic & Manual Shower Power Boosters are supplied with:
 ✓ 1.5 Amp Transformer ✓ 22mm to 15mm Reducing Sets

DOUBLE PUMP PACKS

**SP22S
TWO AUTOMATIC PUMPS**



**SP21S
AUTO & MANUAL PUMPS**



Double Pump Packs are supplied with:
 ✓ 3 Amp Transformer ✓ 22mm to 15mm Reducing Sets
 ✓ Cables to link Two Pumps together

UPGRADE PUMPS

**SP2U
AUTOMATIC PUMP UPGRADE**



**SP1U
MANUAL PUMP UPGRADE**



An Upgrade Pump adds a Second Pump to your existing setup and is supplied with:
 ✓ 22mm to 15mm Reducing Sets ✓ Cables to link Two Pumps together
 ✗ No Transformer, both pumps run from your existing Transformer

RADIATOR FLOW BOOSTER PUMPS

**V1
RADIATOR FLOW BOOSTER**



Based on an original SPB.
 Fits 22mm and 15mm pipes.

**V2
RADIATOR FLOW BOOSTER**



15mm and fits directly to the radiator.

ENERGY STORAGE DEVICE



Fit this device to an existing hot water cylinder to store cheap off peak energy.

GARDEN AND FESTIVAL BOOSTERS



Fully Automatic and Manual Garden Boosters



Fully Automatic Garden Tap Boosters



Boost Direct From A Water Butt



Off-Grid Festival and Pet Showers

WRIGHTCHOICE SHOWER HEADS

A good shower head will maximise the pressure and flow to make a poor shower a good shower, and a good shower a great shower.

At Cranfield University Alan Wright researched shower heads to get the best from a ShowerPowerBooster and one particular shower head design was low cost and gave the best results. He has been selling this design of shower heads since 2012.

Take the guessing out of which shower head to buy and Google 'WrightChoice Shower Heads'.

WrightChoice Shower Heads have a six way adjustable settings to give 112 micro jets for pure showering pleasure. Best on test at Cranfield University, rub clean to clear lime scale, suitable for all water systems. For low pressure, for electric showers, and for combi boilers. Recommended by Alan Wright BSC (Hons) CEng, MICE

If you already have a good shower then the WrigtChoice Shower Head is just a replacement but for some shower mixers with too few nozzles, too fine a nozzle, or just badly designed, buying a WrightChoice Shower Head could be the best investment you make.

<https://wrightchoiceshowerheads.co.uk/>



WRIGHTCHOICE AFFORDABLE HEAT STORAGE DEVICE

A government funded pilot will replace Power Showers with ShowerPowerBoosters and it starts on 1st September 2025. Some homes in Norwich City will enjoy free installation but all homes will enjoy showers at half the cost they are paying today

The full cost of installing an Affordable Heat Store (AHS) and all the work detailed on pages 10, and 11 of this manual is £250. The plumbers will be appointed and paid through pilot schemes in Norwich North, Norwich South, and Norwich City.



WRIGHTCHOICE AFFORDABLE HEAT STORAGE DEVICE

This device fits on top of a hot water cylinder to allow you a full tank of hot water - enough to have all your baths and showers using a cheap off-peak tariff. It could pay for itself in under 9 months.

Tank Recommendation

210 Litre copper cylinder with at least 80mm of factory applied insulation, then wrapped with 3 to 5 layers of High-Performing Multifoil Insulation

WA – Essential 15mm 12 volt actuated valve to stop water consumption at times of peak water demand.

X2 SV – Full bore 22mm lever ball valves

BV – 22mm Blending Valve

CUSTOMER CHOICE (EITHER)

SP22S for Single Boost hot and cold

Or two SP21S for Double Boost hot and cold

WRIGHTCHOICE AFFORDABLE HEAT STORAGE DEVICE

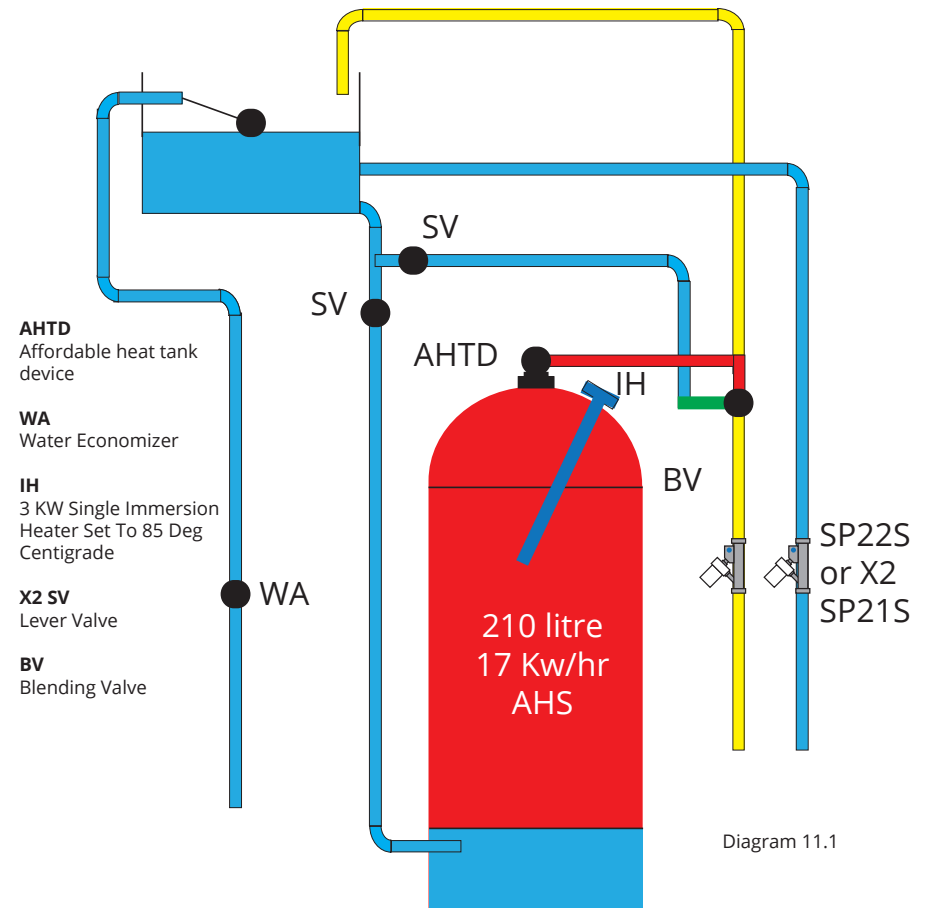

AFFORDABLE HEAT STORE

GENERAL	2 Year Warranty (3 years with SPB Ultimate Care Pack)	
	30 Day Return Policy	
	WRAS Approval - 2002802	
FEATURES	Pump Type	Centrifugal with Brushless Motor
	Inlet Filter	✓
	Dry run protection	✓
	Waterproof	✓
MATERIALS	Body	Brass - BS6282-5
	Pump	Plastic
PHYSICAL	Length	150mm
	Width	45mm
	Height	125mm
	Weight	625g
	Pump Connection	22mm or 15mm Compression
PERFORMANCE	Maximum Head	5.2m to 6m
	Typical Output	5 L/Min @ 3.2m
	Max Sustained Pressure	4 Bars
	Max Sustained Temperature	65 - 85°C
	Min Flow Rate	1.5 L/Min
	Max Flow Rate	9 L/Min
ELECTRICAL	Transformer	12 Volt (1.5 amp or 3.0 amp)
	Input	100 - 240 Volts 50/60Hz
	Output	12 Volts DC
	Power Consumption	12.6 Watts @ 5 L/Min
	Fuse Rating	3 Amp
	Power Cable	3 Pin Plug with 1m AC Cable Male DC Plug with 1m DC Cable

IMPORTANT: DO NOT ADJUST THE MOTOR NUTS. THESE ARE FACTORY SET TENSIONS.

All pumps are tested before shipping but we invite you to carry out pre-fitting checks:

- ✓ Plug in the transformer and you will get a constant blue light.
- ✓ When installed a flashing blue light will indicate a detected flow and the pump is running.

You can check the flow switch yourself by visiting YouTube and search:

'Shower Power Booster - Flow Switch Check'

To run three or more pumps please contact Flowflex

If you do not have 1.5 litres per minute of flow then the pump will not automatically kick in.

- ✓ You can bypass the flow switch by plugging the transformer directly into the white motor.
- ✓ You can then operate the pump by turning the power on and off.
- ✓ You can use the plug, a radio remote, or wire into the lighting circuit to activate the pump.

3 STEP INSTALLATION

A Shower Power Booster can be fitted in most places enabling you to install wherever is most convenient. Pumps are supplied with everything you need to install on either 22mm or 15mm pipe and it takes just 3 simple steps to install:

STEP 1 - Select location for pump & isolate the pipe

The diagrams on the following pages suggest where is best to install the pump for specific applications. Please ensure that the pipework is isolated and free from water before cutting the pipe.

The Shower Power Booster limits the amount of water taken from the hot water cylinder and can only pump up to 9 litres a minute. Shower Power Boosters do not pull in air and there is no need for a Surrey or Essex Flange and no need to drain the hot water cylinder or cold water tank.

STEP 2 - Remove 110mm of pipe, insert the pump & tighten the compression joints.

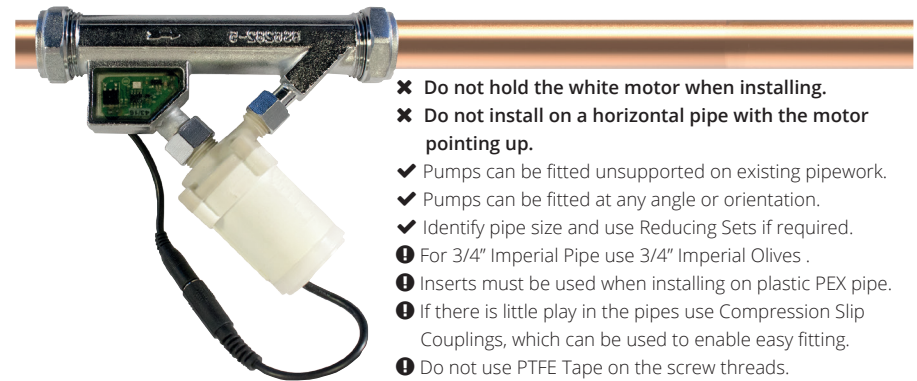

- ✗ Do not hold the white motor when installing.
 - ✗ Do not install on a horizontal pipe with the motor pointing up.
 - ✓ Pumps can be fitted unsupported on existing pipework.
 - ✓ Pumps can be fitted at any angle or orientation.
 - ✓ Identify pipe size and use Reducing Sets if required.
 - ⓘ For 3/4" Imperial Pipe use 3/4" Imperial Olives .
 - ⓘ Inserts must be used when installing on plastic PEX pipe.
 - ⓘ If there is little play in the pipes use Compression Slip Couplings, which can be used to enable easy fitting.
 - ⓘ Do not use PTFE Tape on the screw threads.
- On our website search:
'How To Prevent ShowerPowerBooster Joints Leaking'

STEP 3 - Connect transformer cable to the pump and to a power supply.



Once connected and turned on the LED light on an SP2B will indicate the status of the pump:

- Constant LED light** = Pump has power
- Fast flashing light** = Pump has detected water flow and is running
- Slow flashing light** = Transformer Fault or power protection tripping in and out

Please note: If you have two pumps connected the LED on one pump may shine blue or flash intermittently while the LED on the other pump may continuously flash rapidly - both pumps will be running. This is because the flow rate in one pump is less than 1.5 Litres a minute.

Shower Power Booster pumps can be installed without the need for an electrician. They run off a 12-volt power supply, which allows you to install in bathrooms, where traditional 240 volt pumps would not be allowed.

The transformer can be plugged into the nearest convenient 3-pin socket. You can access sockets up to 15m away from the pump by using our extension cables.

Pumps, which only need 15 watts of power, can also run off an electric light circuit.



FITTING PUMPS IN TIGHT SITUATIONS - A MUST READ FOR SOME

Diagrams 14.1 and 14.2 below show simple DIY solutions to fit the SPBs when pipework beside the hot water cylinder is inaccessible

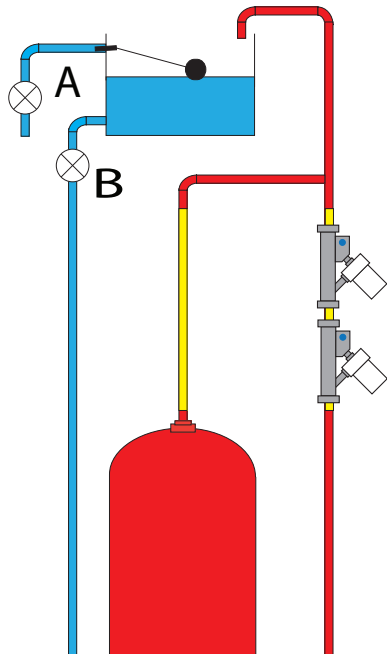

Diagram 14.1

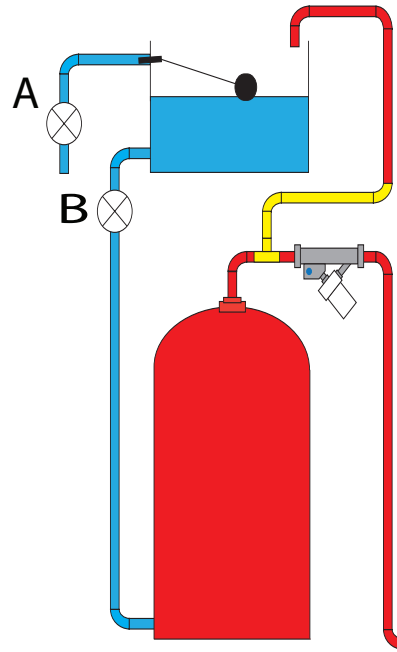

Diagram 14.2

USING A SLIP COUPLING

A 22mm or 15mm Slip Coupling can be used if you need some play on the pipes to fit the pump(s)

Cut the pipe - take out a complete length of pipe and reassemble after having added the pump or pumps. The slip couplings slip over the pipe still in place so you can slip the pipe in and you pull the couplings back to rejoin the pipes when finished. Mark the existing pipes so you know that the coupling covers the cut with the cut being in the middle.



The coupling simply slips over the pipe so you can easily reconnect when the pump is installed.

USING 3 PIECE REDUCING SETS

3 Piece Reducing Sets are supplied with all Shower Power Boosters meaning you can easily install the pump on either 22mm or 15mm pipe.

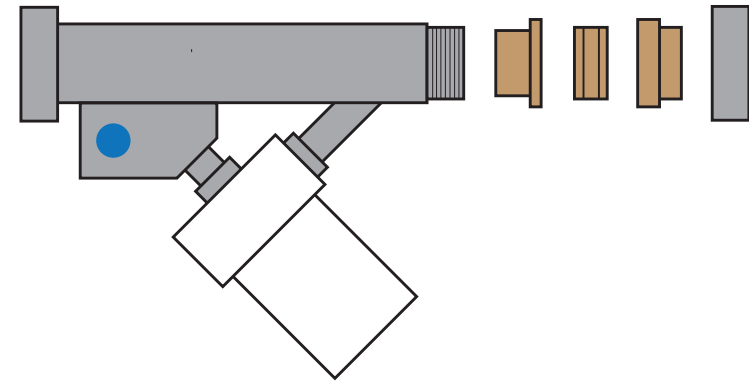

Bush



Olive



Ring

When installing on 15mm pipe you need to use the 3 Piece Reducing Set:

1. Remove 22mm Nut & Olive.
2. Insert the Bush, thin end first.
3. Insert the 15mm Olive.
4. Place Ring on Olive, with the lip resting on the 15mm Olive.
5. Put the 22mm Nut back on and tighten.

CREATING A COMPRESSION JOINT

Compression fittings are designed to mechanically form a joint between the fittings and the pipe. When tightening the nut, you are compressing the olive onto the tube, creating a seal. All Shower Power Booster pumps have compression fittings, so you can easily create a leak free joint when installing the pump.

Some installers use PTFE Tape or Plumbers Mate to help make a leak free joint: although not specifically required, these can be used if used correctly. Image 16.1 shows the two surfaces which need to seal the joint. This is where to use PTFE Tape or Plumbers Mate.

Do not use PTFE Tape or Plumbers Mate on the screw thread, this makes it difficult to tighten the joint, see image 16.2.

Image 16.1 - OK

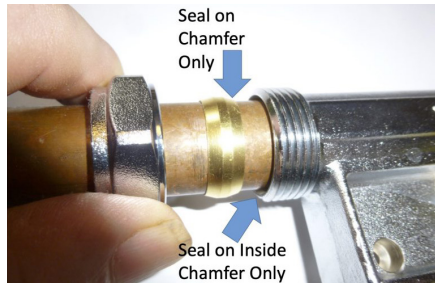

Image 16.2 - NOT OK



FILTERS IN OUR SHOWERPOWERBOOSTERS

All our ShowerPowerBoosters are protected with stainless steel filters which can be simply removed with your finger or a blunt pencil, washed clean, and replaced.

Too much PTFE Tape or Plumbers Mate can block the filter, so if used please use sparingly. Image 16.3 shows the filter.

Image 16.3



28MM PIPE SOLUTION

ShowerPowerBoosters are designed to fit onto 22mm and this is the easiest way of fitting a SPB to 28mm pipe.

SP2B
 2 28mm x 22mm Compression Reducing Coupler
 2 Short lengths of 22mm pipe (40 mm long)
 Total Length 240mm

SP21S
 2 28mm x 22mm Compression Reducing Coupler
 3 Short lengths of 22mm pipe (40 mm long)
 Total Length 240mm + 150mm = 390mm



NEGATIVE HEAD & MANUAL SWITCHING

Diagram 18.1 Showing Negative, Positive & Zero head locations.

Manual Shower Power Boosters can be used for all Negative, Positive & Zero head applications. All Automatic Pumps can be used manually by plugging the transformer cable directly into the white motor. For dealing with negative head, zero head and close to zero head solutions, search on our website:

'Negative Head Shower Power Booster Solutions.'

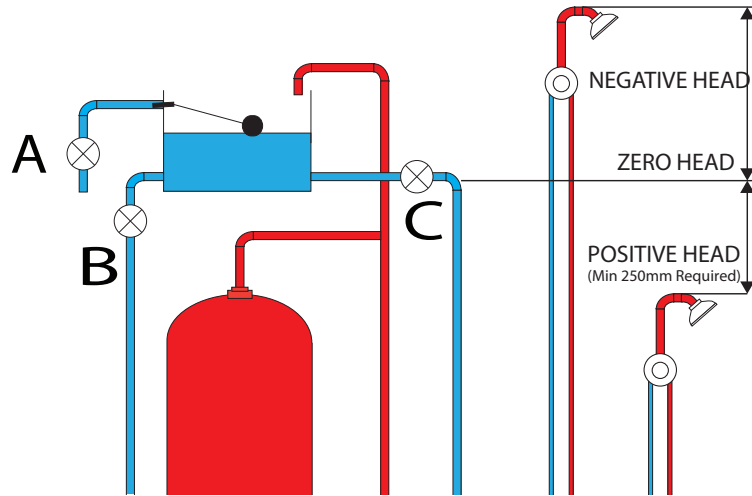

A double boost ShowerPowerBooster (SP21S) is great for negative head situations, zero head situations, and situations where there is the minimum of positive head if you adopt a simple way of turning a pump on and off. Each pump takes only 12 watts of power so the transformer will not overload a lighting circuit so wired into a lighting circuit it can operate whenever a light is switched on and off even with a twin pump set.

- 1.0 The simplest way is to turn the transformer on and off at the plug socket.
- 2.0 The pumps take 12 watts each which is far less than a 100 watt light bulb so you can wire the transformer into the light switch or fan and it comes on and off with the lights or the fan.
- 3.0 An elegant solution is to buy a radio remote to switch the pumps on and off.

You need a minimum flow of 1.5 litres a minute for automatic operation of our pumps

DOUBLE FLOW OR TRIPLE FLOW

The Shower Power Booster can be installed anywhere within the house, including in a shower room and in the loft. Pumps do not cavitate or pull air from the vent pipe so you can install wherever is easiest to fit. If you are struggling to get two pumps close together or installing in different rooms you can still link them together using low voltage DC extension cables.

It is required that 22m single check valves (NRV) are installed on the pipeline legs on which the SP1U pumps are fitted

Diagram 19.1

Double Flow Option
 $F + F = 2F$

SP2B + SP1U = SP21S

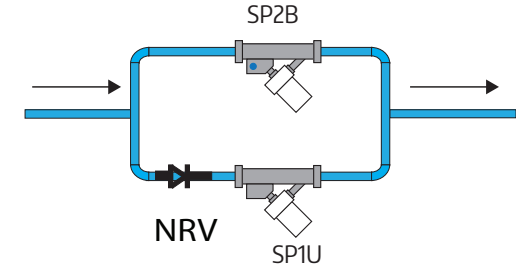

Diagram 19.2

Triple Flow Option
 $F + F + F = 3F$

SP2B + SP1U = SP21S + SP1U

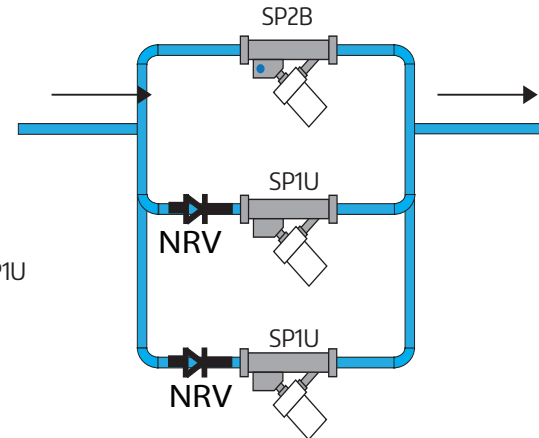
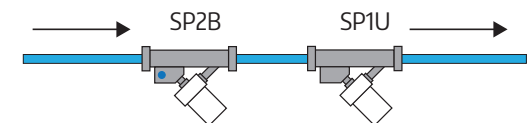

Diagram 19.3

Double Pressure Option
 $P + P = 2P$

SP2B + SP1U = SP21S



DOUBLE BOOSTING HOT & COLD

We have customers who have taps and showers which are very demanding and they want to continue using that particular tap or shower.

To get mains pressure hot and mains pressure cold this is the solution for you:-

Buy two SP21S (Or two SP2B plus two SP1U).
A SP21S consists of an automatic pump and a slave pump with a 3amp transformer so it is a cheaper way to buy your pumps.

Each automatic pump will need its own 3 amp transformer.

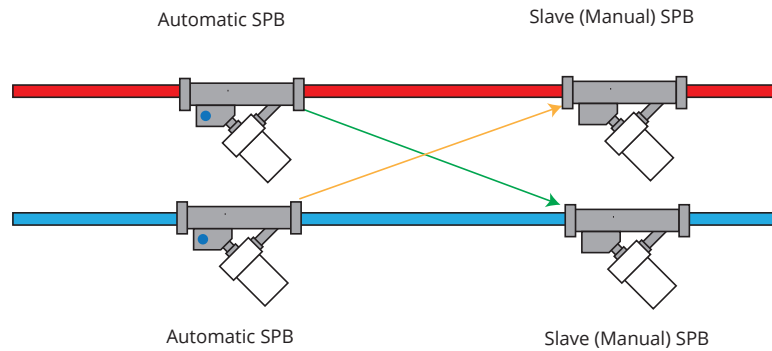

Diagram 20.1

Fit one automatic pump on the hot pipe and its slave on the cold pipe.
Fit one automatic pump on the cold pipe and its slave on the hot pipe.

A SINGLE AUTOMATIC PUMP - SP2B

Connect the female socket on the chrome body on pump to the male connector on the transformer

Diagram 21.1

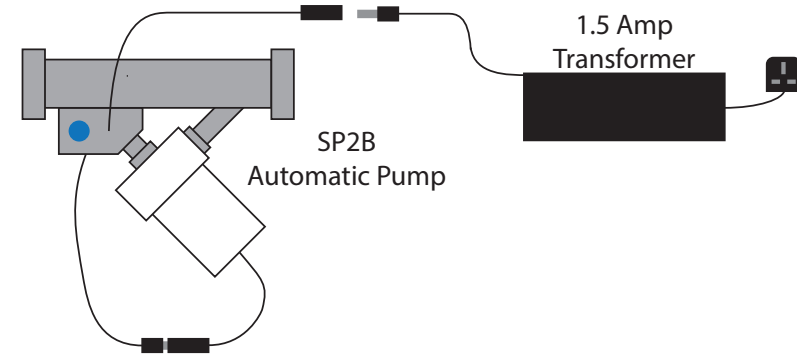

SP21S - ONE AUTOMATIC & ONE MANUAL PUMP (or SP2B & SP1U Upgrade Pump)

Double Boost: Two pumps on hot or cold feed provides a double boost

Diagram 21.2

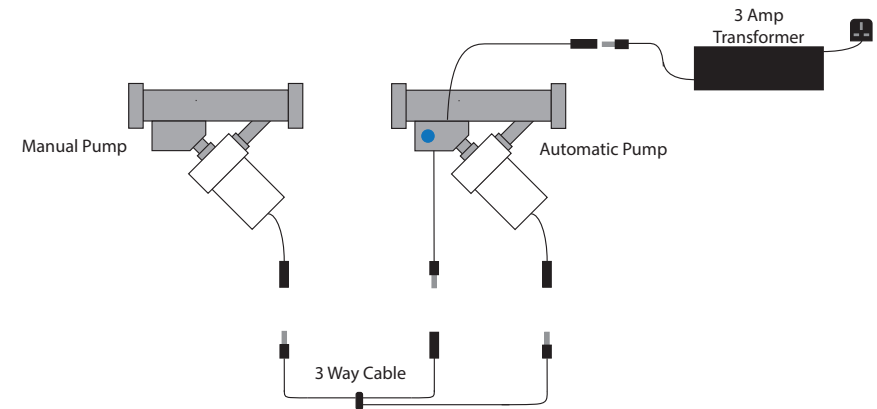

The order in which pumps are fitted does not matter.

SP22S - TWO AUTOMATIC PUMPS (or SP2B and SP2U Upgrade Pump)

Balanced Flow: Boost both Hot & Cold Gravity Feeds

Diagram 22.1

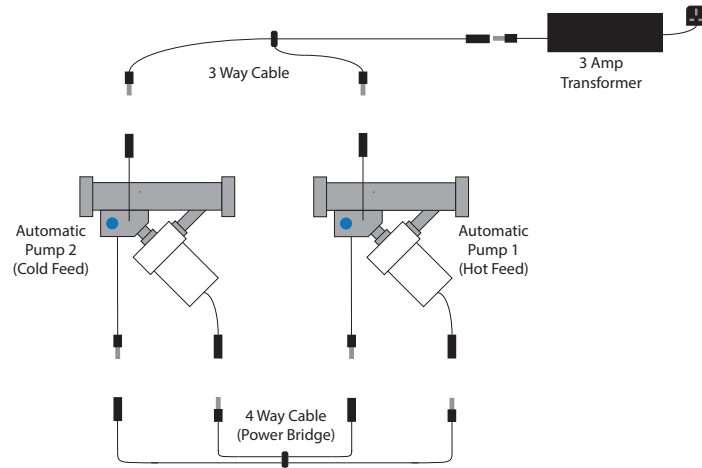

WIRING DIAGRAM WITH EXTENSION CABLES

Required for SP22S when pumps are over 1m apart

Diagram 22.2

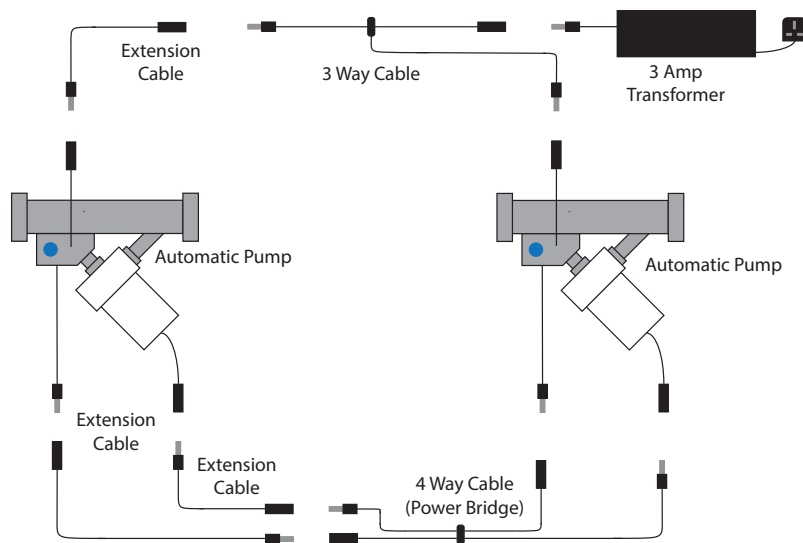

WHOLE HOUSE SOLUTION

For gravity systems, our whole house solution is the most popular choice. Installing a pump next to the hot water cylinder, but after the vent pipe, will boost the flow rate for every tap, shower & application in the house.

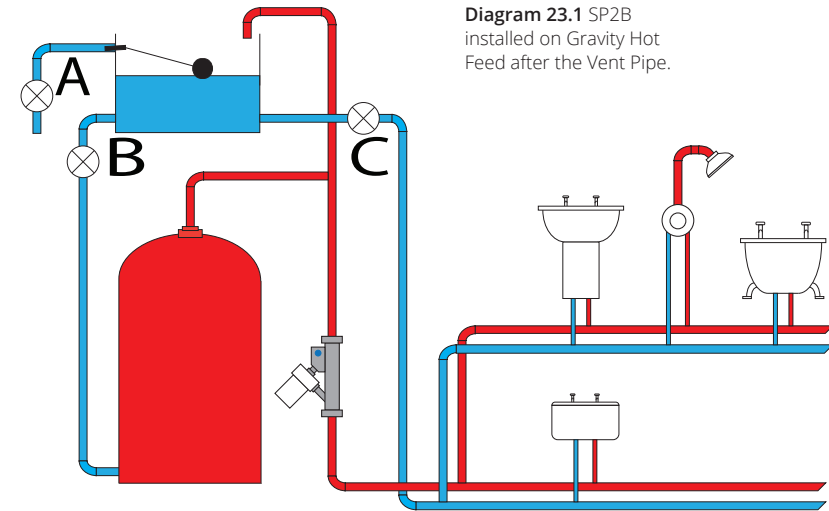

Diagram 23.1 SP2B installed on Gravity Hot Feed after the Vent Pipe.

PROTECTED FLOW SOLUTION

Sometimes there is just one tap, shower or application which is letting you down with poor flow rates & low pressure. The Shower Power Booster does not cavitate so you are able to install it on the feed which only supplies a specific tap or shower. This will not only improve the flow for the specific outlet, it will also maintain the flow even if other taps are being used in the home.

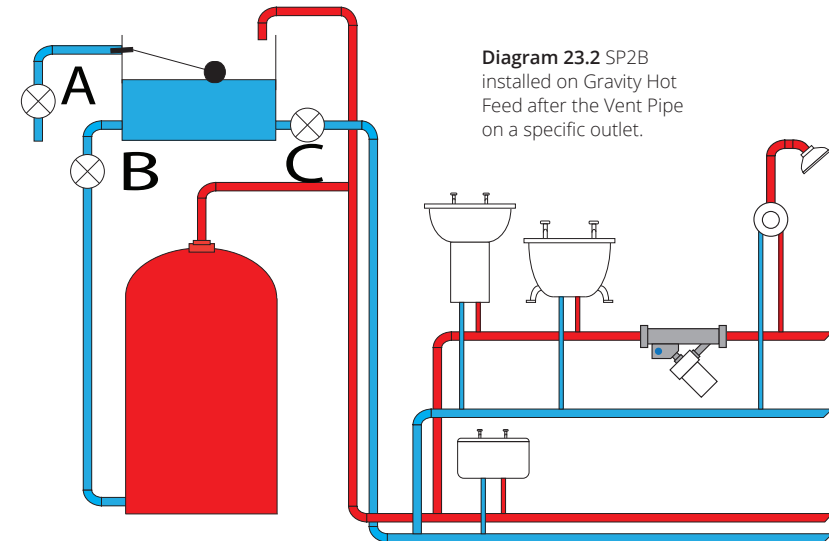

Diagram 23.2 SP2B installed on Gravity Hot Feed after the Vent Pipe on a specific outlet.

BALANCED FLOW SOLUTIONS

A single Shower Power Booster is sufficient for most installations. A good shower or tap mixer should be able to cope with pressure differentials of up to 4 to 1.

If your hot and cold supplies are both very low gravity pressure, or your mixer struggles to balance pressures, then you may need to install a pump on both the gravity hot and cold feeds. This will not only improve all water outlets, but will also keep the system balanced.

WHOLE HOUSE BALANCED SOLUTION - GRAVITY HOT AND COLD

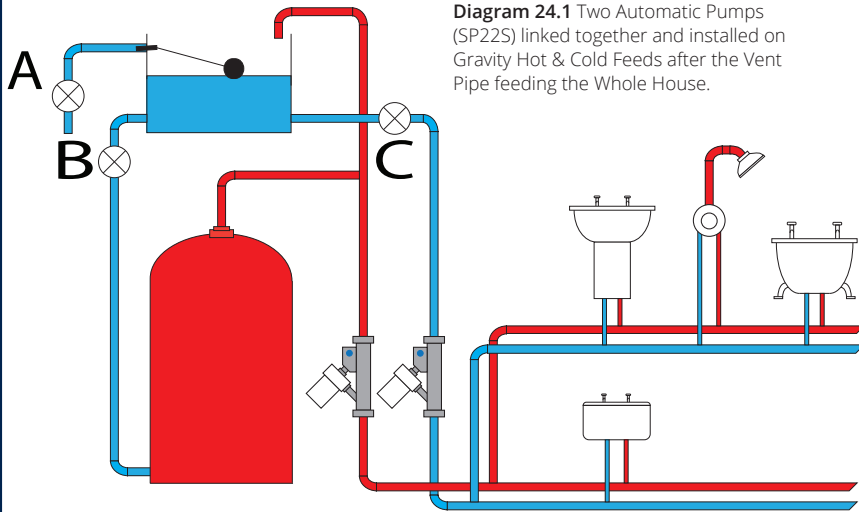

Diagram 24.1 Two Automatic Pumps (SP22S) linked together and installed on Gravity Hot & Cold Feeds after the Vent Pipe feeding the Whole House.

KITCHEN TAPS

All kitchen taps are mains water cold so to balance mains pressure you are better to double boost the hot with a SP21S near the hot water cylinder or near the kitchen tap.

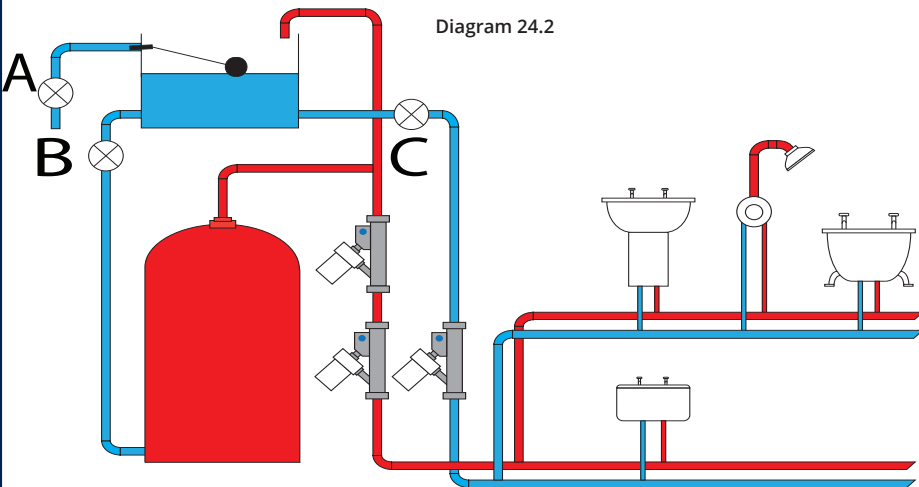
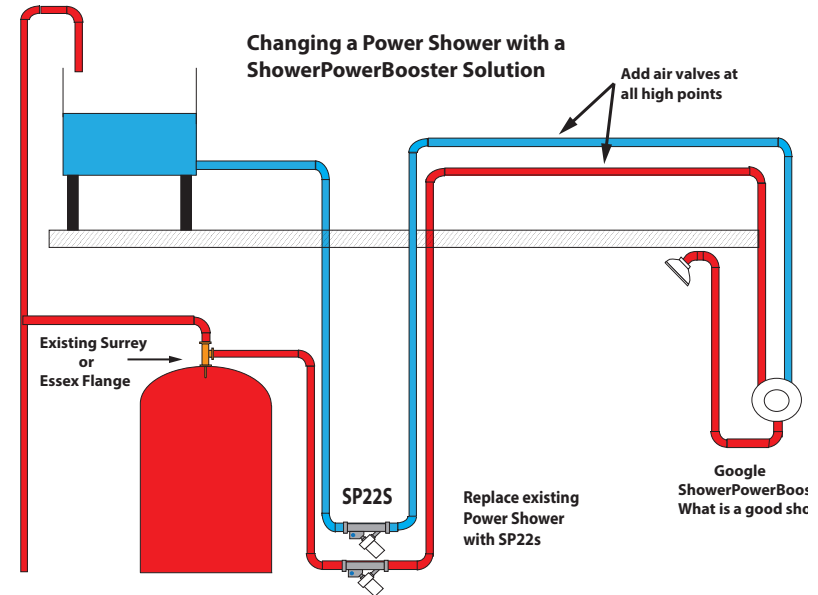

Diagram 24.2

Diagram 25.1



Please read my blog pages written as a result of customers reporting back on their experience of replacing their own Power Showers:-

“Replacing a traditional Power Shower with a ShowerPowerBooster”
 “Two 15 watt ShowerPowerBoosters have the same effect as a 3KW Power Shower”

It is a leap of faith to replace a big power shower with two tiny ShowerPowerBoosters, but the science dictates that the perfect shower is one that has a pressure of 2 - 3 metres and a flow of 5 - 6 litres a minute: enough pressure to give a good spray pattern combined with enough flow to wash away suds. Perfect because at that flow and pressure and with a good shower head, it saves time, water, and the cost of heating that water.

Many shower heads will not deliver much more than 6 litres a minute so the harder a power shower pushes the more a shower head resists and the more energy is simply wasted. If a particular shower has a shower head which allows 12 litres a minute, the cost is twice that of a 'perfect shower'. Please check your flow.

This technology reduces water bills, and energy bills, and the sooner you can replace your power shower with a SP22S or two SP21S the quicker they will pay for themselves.

To switch your house to 100% renewable energy please refer to page 9.

MIXED FLOW SOLUTION FOR WHOLE HOUSE

If you have a gravity hot feed and a mains fed cold feed then you have a mixed system.

If your mains fed cold is higher than the gravity hot side and you are having issues due to this imbalance you will need an SP1U Shower Power Booster to give the gravity hot side an extra boost.

Diagram 26.1 Automatic & Manual Pumps (SP21S) linked together and installed on Gravity Hot giving a Double Boost to Balance against a Mains Fed Cold supply.

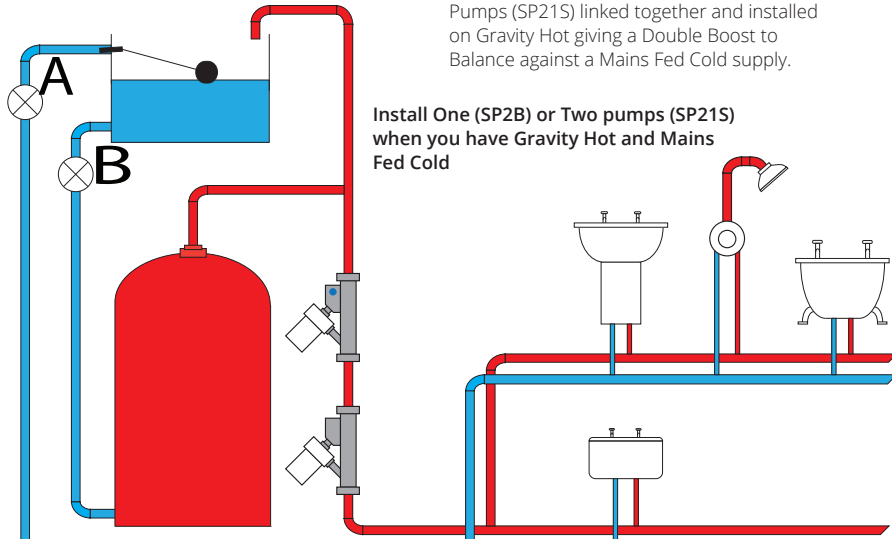

Install One (SP2B) or Two pumps (SP21S) when you have Gravity Hot and Mains Fed Cold

PROTECTED FLOW SOLUTION (GRAVITY HOT AND MAINS COLD)

You can combine a 'whole house solution' with 'protected flow solutions'

Diagram 26.2

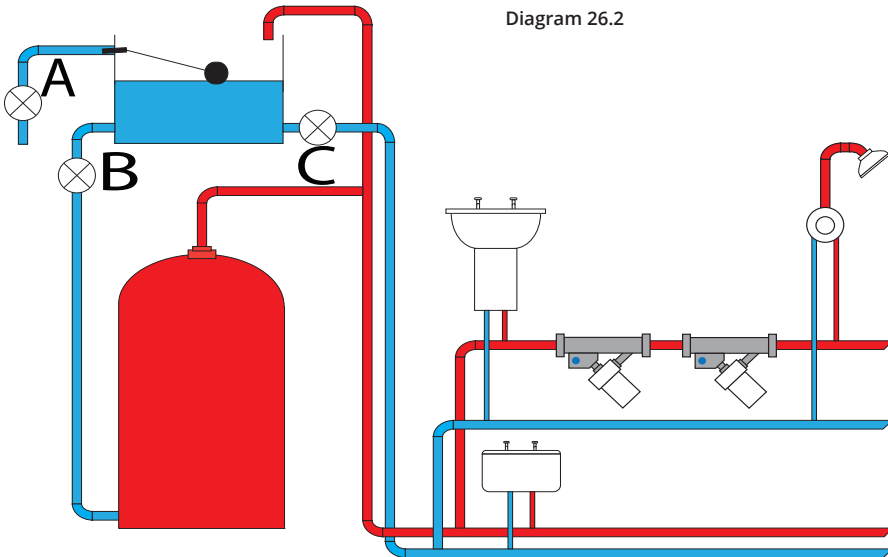

FORTIC AND CLOSE COUPLED TANKS MIXED SYSTEM

The Shower Power Booster is the only pump recommended for Fortic & Close Coupled Tanks

Diagram 27.1 Automatic & Manual Pumps (SP21S) linked together and installed on gravity hot giving a double boost to balance against a mains fed cold supply.

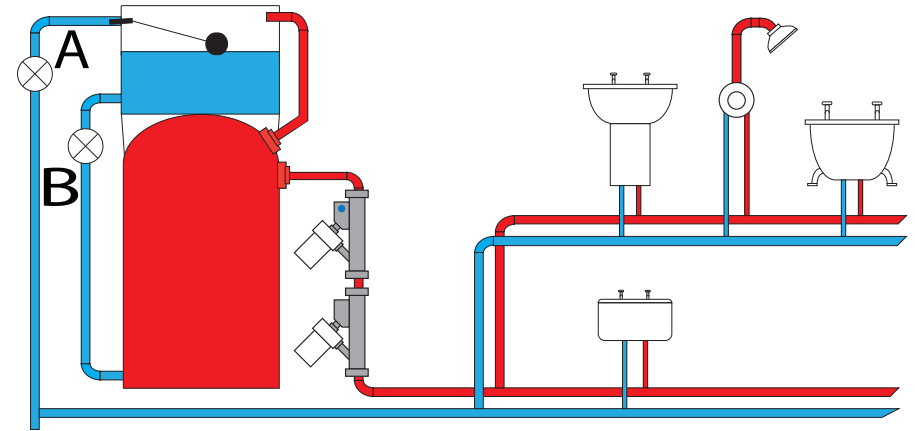

FORTIC AND CLOSE COUPLED TANKS GRAVITY HOT AND COLD

Diagram 27.2 Two Automatic Pumps (SP22S) linked together and installed on Gravity Hot & Cold Feeds.

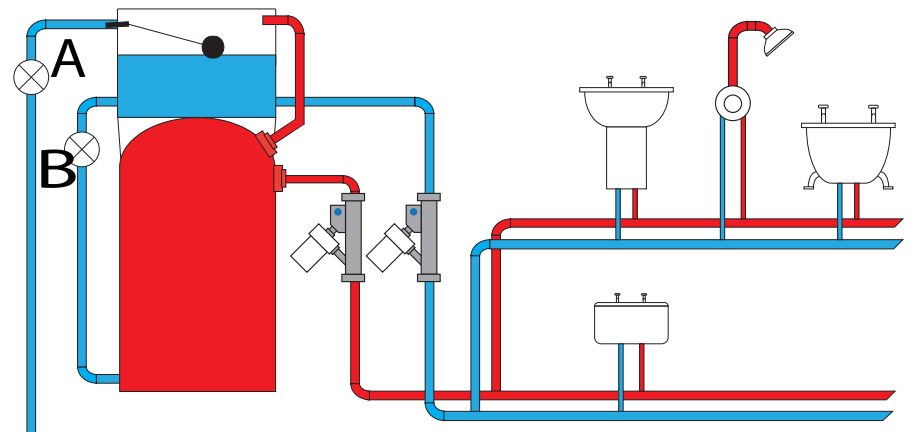

LOW MAINS WATER PRESSURE

The Shower Power Booster holds WRAS Approval and has a maximum flow rate of 9 litres per minute meaning it can be legally fitted to the incoming mains cold supply to increase the pressure and flow rate.

A double pump SP21S can be installed directly after the internal stop tap to give the mains water pressure a boost. Two pumps fitted on a loop on the incoming cold pipe, after the stop tap is often the perfect solution for low mains water pressure, see diagram 28.1.

The SP21S is two pumps which connect and run together from a single transformer. Together the pumps add up to one bar of pressure but neither pump can pull more than the legal limit of 12 litres per minute.

Diagram 28.1 Shows how to fit two pumps in series when there is limited space and applies to all applications of the Shower Power Booster.

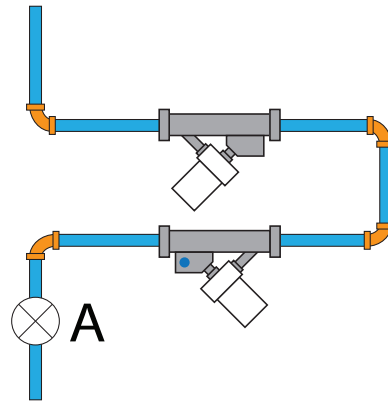

ELECTRIC SHOWER SOLUTION

All electric showers are fitted with a pressure sensor and if the pressure of the incoming mains cold water supply falls below 0.8 Bar, the electric shower will switch off heating elements and you will be left with a cold shower or boiling hot water. Adding a Shower Power Booster will increase the pressure and flow rates to stop this from happening. If your incoming cold water supply is exceptionally low then you may need to add a second pump to double boost.

Although a Shower Power Booster will keep your electric shower active, it is important to note that all electric showers are limited by the KW rate to the amount of water it can heat. We would therefore advise that you measure the flow rate at maximum hot (42°C) from your electric shower as you may already be getting the maximum flow rate from your electric shower:

7.5 KW	Electric Shower	3.5 litres a minute - Single Boost SP2B should sort it
9.8 KW	Electric Shower	4.7 litres a minute - Double Boost SP21S should sort it
12.5 KW	Electric Shower	6.0 litres a minute - Double Boost SP21S should sort it

Diagram 28.2 Automatic Pump (SP2B) installed on Mains fed cold to an Electric Shower.

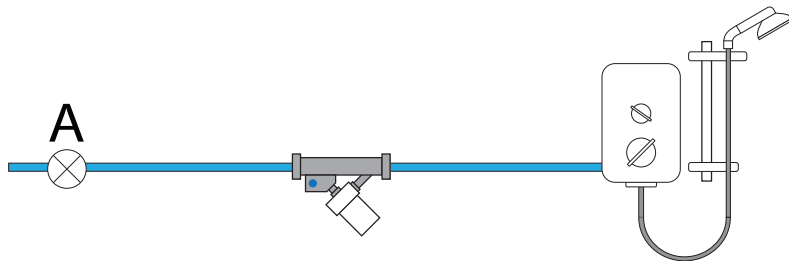

A simple test is to run the shower at full hot and cold, if the cold is much greater than the hot then it is possibly not a pressure problem.

COMBINATION BOILER SOLUTION

Combination boilers are fitted with a pressure sensor and if the pressure of the incoming mains cold water supply drops below 1.0 bar the gas is turned off. The Shower Power Booster can be legally fitted to the incoming mains cold supply to increase the pressure and flow rate to stop this from happening when boosting a shower.

In most cases a double pump SP21S is enough to keep the boiler active by adding around 0.4 to 0.6 Bar to the pressure, preventing the combination boiler from falling below 1 Bar.

Although the output of a combination boiler greatly exceeds the output of a Shower Power Booster, you can still expect to protect flow rates of 6 litres a minute to showers and around 8.5 litres a minute to mixed flow to taps.

WHOLE HOUSE SOLUTION

Diagram 29.1 Automatic & Manual Pumps (SP21S) linked together and installed on Mains fed cold to a Combination Boiler.

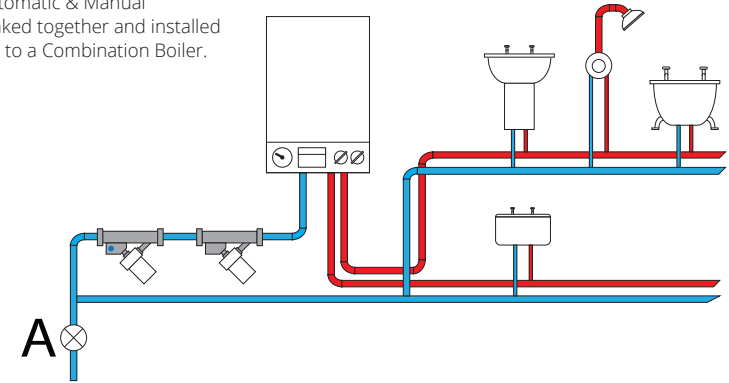

PROTECTED FLOW SOLUTION

A Shower Power Booster works on the hot side of any Combination Boiler to boost & protect a shower or tap. It increases the flow and gives that flow priority over other taps being used.

For demanding situations a pump on the hot and cold may be required (SP22S).

Diagram 29.2 Automatic Pump (SP2B) installed on the hot feed to two showers. If the cold also needs protection fit a SP22s for each shower

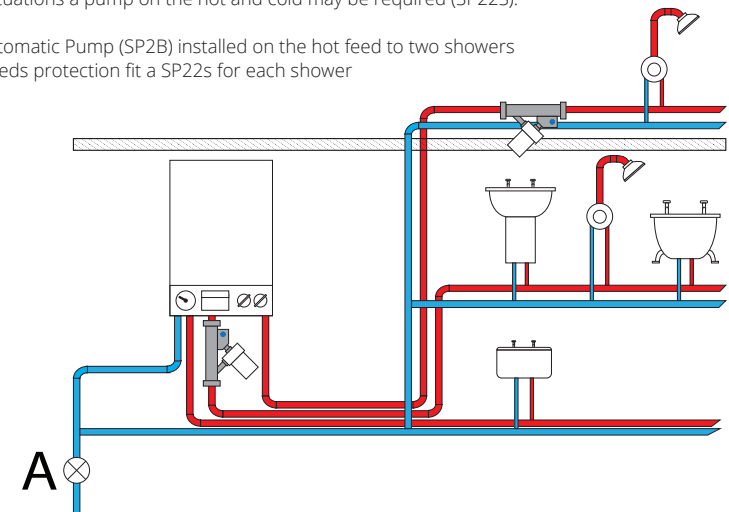

BOOSTING UNVENTED HOT WATER SYSTEMS - WHOLE HOUSE

It is perceived wisdom that people who install unvented hot water cylinders no longer have pressure problems and this is true for most but this still leaves thousands of homes that do have pressure problems. The ShowerPowerBooster is the only pump designed to boost either the hot or cold sides of an unvented hot water cylinder or both.

BOOST THE HOT AND THE COLD

If a home suffers from fluctuating mains pressure it is possible to double boost the mains feed to the whole home (See Diag. 30.1), just double boost the incoming cold water feed to your home. This will boost all cold and hot taps equally.

Diagram 30.1 Shows how to fit two pumps in series when there is limited space and applies to all applications of the Shower Power Booster.

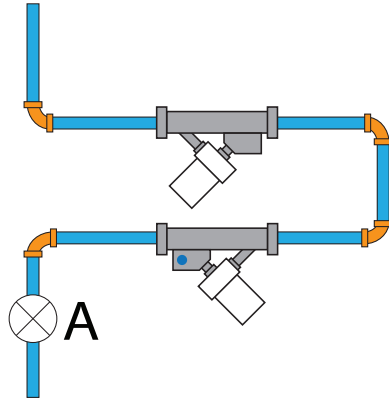

BOOST JUST THE HOT

To boost just hot water install a SP21S near the unvented cylinder. Two pumps, before or after the cylinder are equally effective, however customers have found the easiest way to fit the pumps is to fit one either side of the cylinder (as shown)

Diagram 30.2

Automatic & Manual Pumps (SP21S) linked together and installed before and after the cylinder.

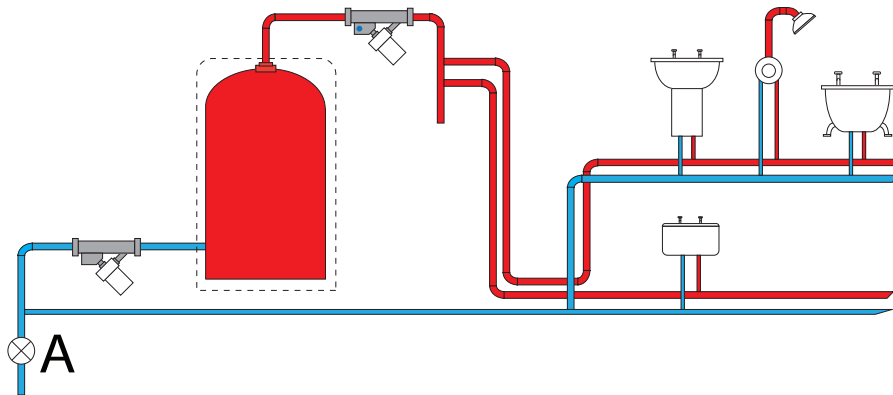

BOOSTING UNVENTED HOT WATER SYSTEMS - PROTECTED FLOW

(PROTECT AND BOOST THE FLOW TO A SINGLE TAP OR SHOWER)

The main feed from the hot water cylinder branches off to supply multiple taps and showers. If it is a particular tap or shower that you want to boost and protect then you need to fit a pump on the pipe that only feeds that tap, shower or bathroom. If it is just the hot that fluctuates, a SP2B should sort it.

Diagram 31.1

If only the hot pressure fluctuates then a single boost SP2B on the hot should sort it. You may wish to opt for a double boost SP21S or if the cold pressure also fluctuates you will need a SP22S giving you linked automatic pumps on the hot and cold.

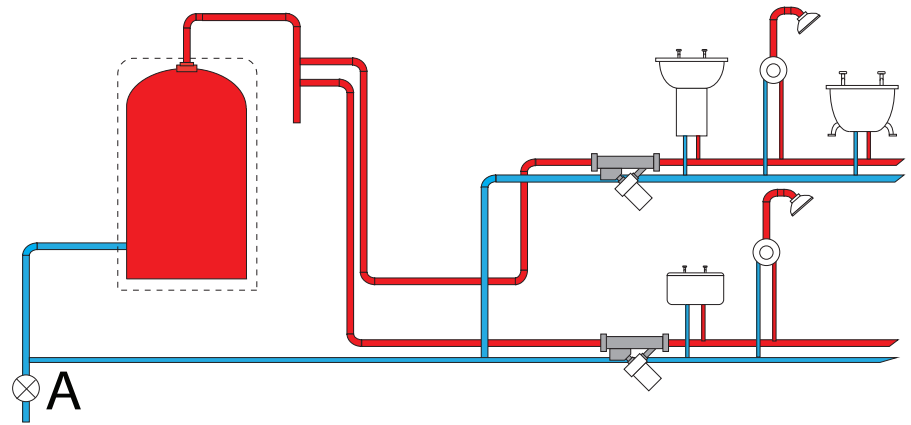

If the cold also needs protection, fit a SP22s for each shower

INSTANT HOT WATER AT TAPS AND SHOWERS

Our in-line micro pumps will provide hot water recirculation to give "instant" hot water to showers and taps. They work equally well for vented and unvented systems although a non return valve is not required for unvented systems. They have been installed in homes and even in a large factory. With this in mind we supply a pump flow-rated for your specific requirement.

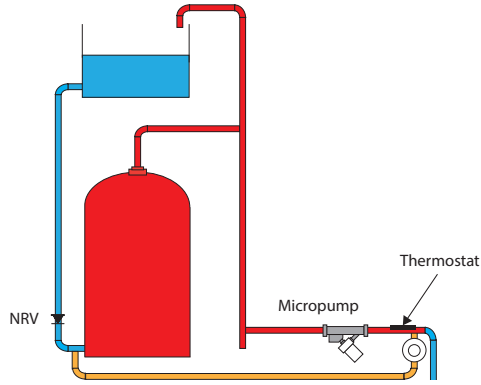
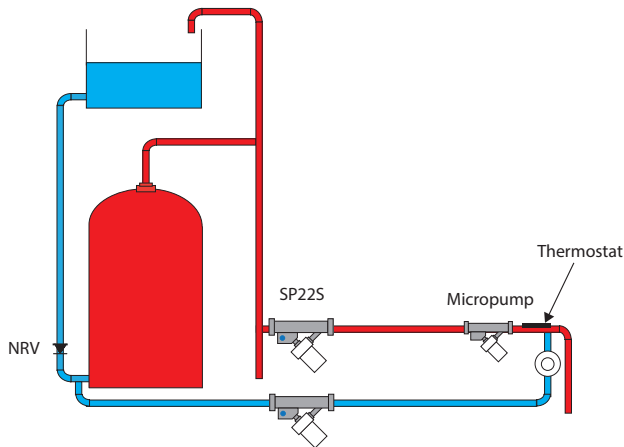

Diagram 32.1
This diagram above illustrates the components and the temperature of the pipes when hot water recirculation is active

Diagram 32.2
If you want to boost the flow and pressure as well as recirculation add a SP22S to the flow and return as shown



INSTALL OF PUMPS IN LOFT

ShowerPowerBoosters can be installed anywhere. Many showers are added after a home was built so they will have pipes which run across a loft and down to the shower. The ShowerPowerBooster is an easy install because you have the option in all cases to fit the pumps in the loft or close to your hot water cylinder even when the pipes are in the loft.

You can fit the pumps next to the hot water cylinder even if the pipes run across the loft.

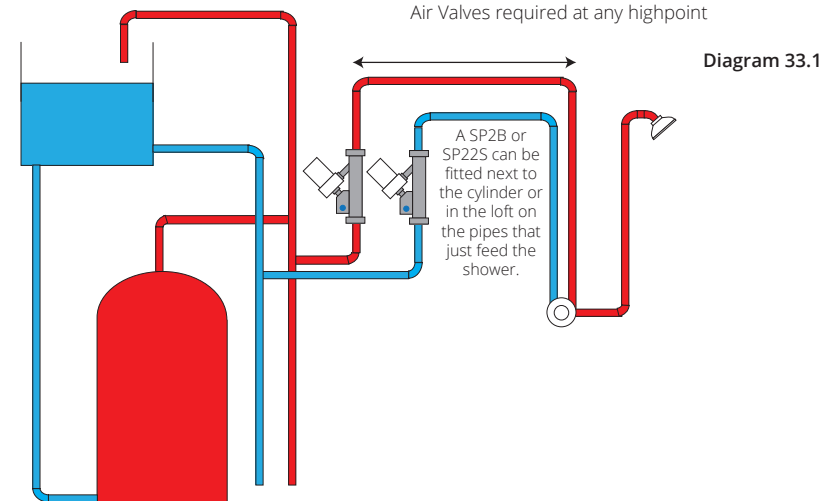

Diagram 33.1

If it is easier to fit a SP2B or a SP22s in the loft then fit the pumps in the loft.

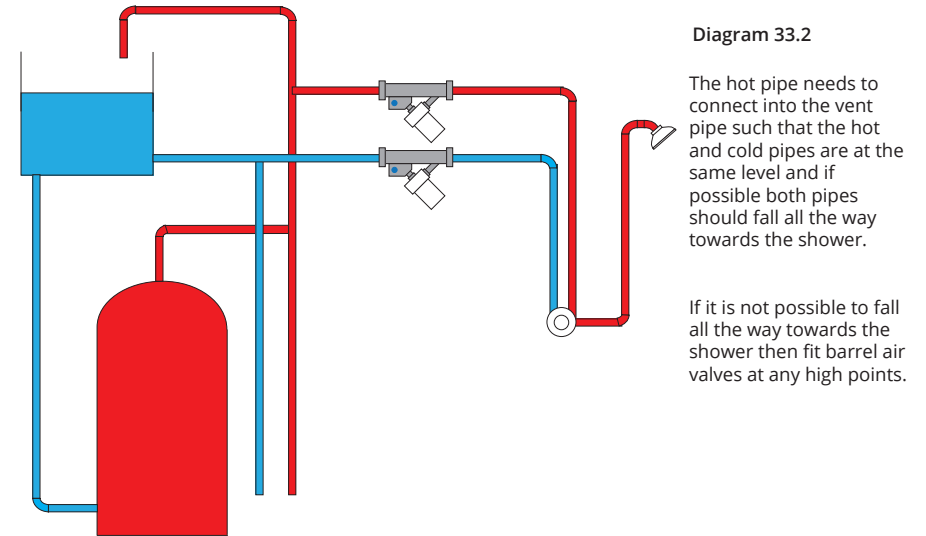

Diagram 33.2

The hot pipe needs to connect into the vent pipe such that the hot and cold pipes are at the same level and if possible both pipes should fall all the way towards the shower.

If it is not possible to fall all the way towards the shower then fit barrel air valves at any high points.

If you need power in the loft you can buy a 3 metre low voltage extension cable from us.

INSTALL UNDER A BATH

Fitting a pump under the bath is ideal if you only have a problem with the bath taps or shower over the bath. Fitting the pumps under the bath also has the added advantage in that in fitting them here, when other taps are used in the house, the pump maintains pressure to the shower above the bath.

You can continue to shower without the fluctuations in pressure and temperature you would have without the pump. The pump takes priority over other taps to maintain pressure and flow to the shower.

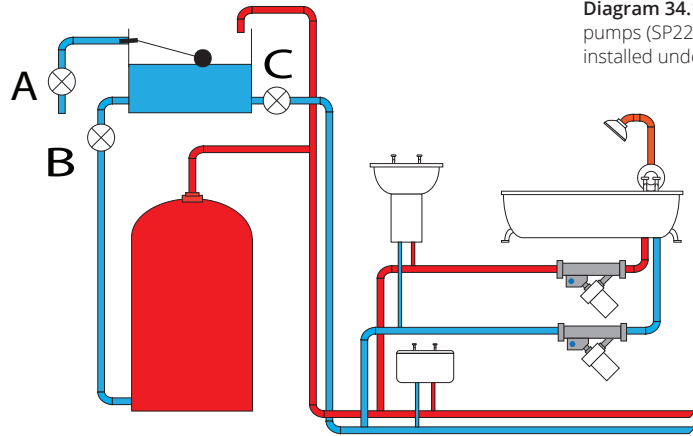

Diagram 34.1 Two Automatic pumps (SP22S) linked together and installed under a bath

LOFT CONVERSIONS

It is so very easy to get a pressurised hot water supply to a loft conversion without raising your cold water tank and from an existing gravity system if you can plan ahead. If the shower head or bath is below the water level of the cold tank you will be able to use the fully automatic SP21S. If the bath or shower head is above the cold water level in the cold tank the automatic option is unlikely to work so you need the SP1 plus a SP1U.

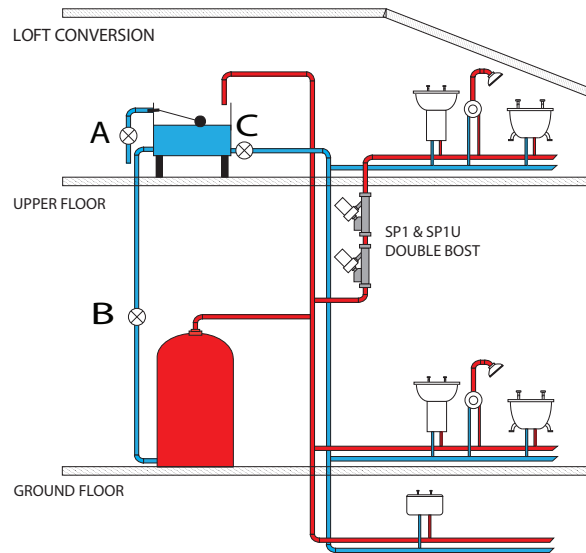

Diagram 34.2

DOWNSTAIRS HW CYLINDER (MULTIPLE FLOORS)

What is an Upside Down House?

An upside down house is a house on multiple levels with a hot water cylinder on the ground floor. For cold water it is normal to supply all floors in such houses from a cold water pipe connected to the cold water tank in the loft. For hot water it is normal to supply all floors from a hot water pipe connected to the hot water cylinder through a pipe that doubles up as a vent pipe as well.

The problem in boosting a combined hot pipe is that adding pressure to a vent pipe will simply pump hot water into the cold water tank. There are several boosting solutions.

OPTION 1

Boost the individual hot and cold pipes close to the showers and taps you need to boost.

OPTION 2

Install a separate vent pipe from the hot water cylinder into the top of the cold water tank. You will find the hot and cold water pipes are boxed in and there is a clear route all the way from the ground floor to the loft.

Cap off the existing vent pipe so that the existing pipe which was a combined feed and vent pipe is now a dedicated feed pipe so you can boost this pipe. A single boost SP2B fitted on the dedicated feed pipe near the cylinder should suffice.

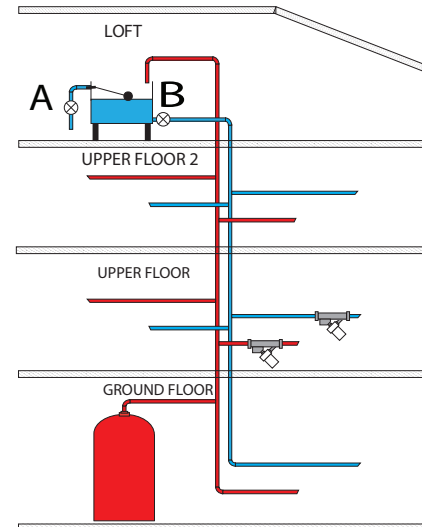

Diagram 35.1

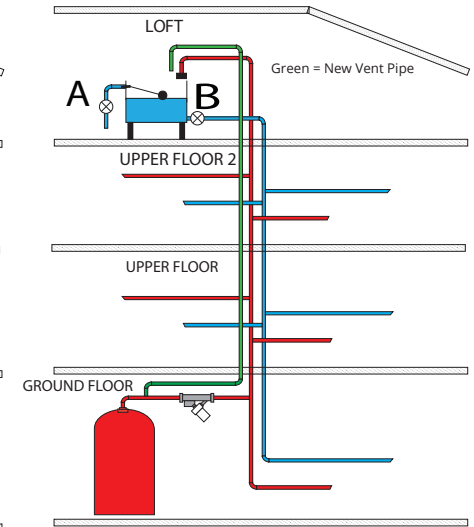

Diagram 35.2

TREVI BOOST

A Trevi Boost is a clever way of boosting a gravity hot, taking pressure from a mains feed cold, and giving this to the hot.

It is a bit hit and miss as, if your hot pressure is too low to start with or the mains pressure fluctuates, or the temperatures vary, then your shower will suffer.

A ShowerPowerBooster works in harmony with your Trevi Boost and will always improve and stabilise your shower even if the cartridge is due for replacement. Leave your Trevi Boost in place and just fit a SPB – It always works.

See what our customers say:

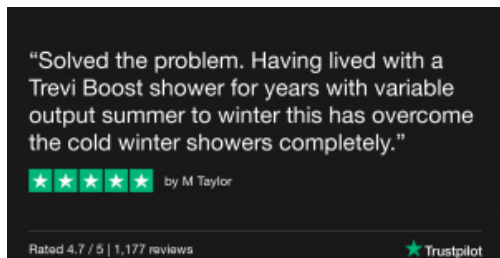

TrustPilot review - M Taylor 14th February 2021



- I have a pair of Trevi Boost showers which use cold water pressure to enhance the hot, they're good but not that powerful. On one of Trevi's troubleshooting sites an expert there suggested your power boosters to further power up the hot water. Following extensive viewing of Alan Wright's various videos, I decided to take the plunge! My plumber had never heard of the booster so I forwarded him the videos and he had no problem fitting the SP21S to all the hot water side. Wow, what a difference. Generally throughout the house very much improved flow, however the shower is a torrent! 6 litres-a-minute before to 17 litres-a-minute now. Thanks Alan, glad I took the plunge.
Phil Cowell 14th Jan 2021
- We had a Trevi Boost system installed some years ago (uses mains water pressure to draw hot water through the shower using the venturi principle). It was always a bit borderline because we have a very small head from the hot water tank, and shower was often lukewarm. I've just installed an SP2 pump on the hot feed to the shower, and it's solved the problem – shower now works brilliantly. Pump takes up minimal space in the airing cupboard, was easy to install, and was delivered very quickly. Thanks for a great product!
David Jarratt 19th September 2018

NOTE FROM THE INVENTOR

A single boost SP2B will assist a Trevi Boost if it is not performing well, but a single SP2B will allow you to enjoy a great shower even if the Trevi Boost is broken, so you can leave the old Trevi Booster in place. Just refer to the mixed gravity hot and mains pressure solutions in this manual and perhaps pay the small premium to upgrade to a SP21S.

FAULT FINDING, DIAGNOSTICS, AND SOLUTIONS

Please refer to the advice in this manual. You can also access additional online advice by a Google search using the single word **ShowerPowerBooster** followed by the page title.

Check the wiring diagrams on pages 21 and 22 and if it helps you can wire up any pump to operate manually by bypassing the flow switch (see diagram 37.1)

PUMP NOT KICKING IN?

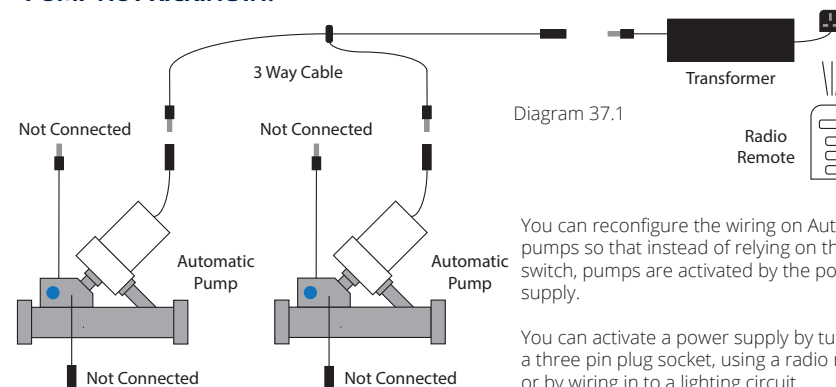

A ShowerPowerBooster is fitted into an existing plumbing system which may have existing issues which may change over time as air accumulates, temperatures change, valves jam open, sediment accumulates, and other factors unrelated to the pump change. This issues could be:

- Air accumulating in pipes before the pump causing the pumps to starve.
- Air accumulating in pipes after the pump causing back pressure.
- Temperature of the hot and cold.
- Anti Scald valves in mixers.
- Fluctuating mains pressure.
- Non return valves at mixers jamming open.
- Back pressure in the shower head or shower hose.
- Calcium build up in shower head causing back pressure.
- Shower mixer unable to deal with different hot and cold pressures.
- Back pressure in the mixer itself.
- Sediment in filters.
- Sediment in a cold water tank.
- Sediment in a hot water tank.
- Valves not opened or restricting flow.

All pumps are tested before shipping but we invite you to carry out pre-fitting checks:

- ✓ Plug in the transformer and you will get a constant blue light.
 - ✓ When installed a flashing blue light will indicate a detected flow and the pump is running.
- You can check the flow switch yourself by visiting YouTube and search: 'Shower Power Booster - Flow Switch Check'

To install three or more pumps please contact Flowflex

If you do not have 1.5 litres per minute of flow then the pump will not automatically kick in.

- ✓ You can bypass the flow switch by plugging the transformer directly into the white motor.
- ✓ You can then operate the pump by turning the power on and off.
- ✓ You can use the plug, a radio remote, or wire into the lighting circuit to activate the pump.

HAS THE PUMP STOPPED OR STOPPED WORKING AUTOMATICALLY?

A constant blue light indicates the flow switch has power.

No light indicates a failed transformer.

A fast flashing light but the pump not running indicates a failed pump.

A slow flashing light indicates a failed transformer or failed motor.

Check the socket by trying to run the pump in manual mode (the pump vibrates when it is running).

IS THERE INSUFFICIENT FLOW TO START THE PUMP?

A fast flashing blue light indicates a flow above 1.5 litres a minute.

A constant blue light indicates there is not enough flow to switch the pump on

Check the flow rate by collecting the flow over one minute (1.5 litres weighs 1.5kg)

Increase the flow rate by cleaning your shower head (or buy a more effective shower head), check and clean the filters.

AIR IN THE SYSTEM

A rapidly flashing blue light interspersed with short periods with a steady blue light indicates air in the system. Run the system at full hot to try to push the air from the system, remove the shower head to increase the flow. Check your system for high points and fit bottle air valves at any high points or reconfigure your pipework. The air can be anywhere in the system provided it is pressurised by the pump. Check for high pressure mains water crossing from cold to hot at a mixer tap/shower. This will be indicated by water overflowing from the cold tank in the loft. The solution is to fit a 22mm single check valve next to the SPB.

NON RETURN VALVES

A rapidly flashing blue light interspersed with new short periods with a steady blue light also indicates a failed non return valve in the system but this time it could be hot water crossing from the hot to the cold or cold water crossing from the cold to the hot. If you feel warm water returning via the cold pipe fit a non-return valve on the cold pipe, if not fit it on the hot pipe, if in doubt one on the hot and one on the cold.

THE PUMP PULSES

A ShowerPowerBooster will supply up to 8 litres a minute. If there is insufficient water reaching the pump, the pump will be noisy with the volume and tone increasing and decreasing. Open the tap to maximum hot. Check the flow rate by collecting the flow over one minute (1.5 litres weighs 1.5 kg). If you cannot get 8 litres of water from one tap open up 2 or 3 taps and check the flow from both at the same time.

Search on Google for 'ShowerPowerBooster Pulsing Pumps' for a more information and detailed solutions.

There are some shower mixers which work much better than others. Search ShowerPowerBooster Review Of Best Mixer Showers. The best mixer showers are not the ones that look nice but the ones that look nice and give you a good shower. You need to ask the right questions before you buy a mixer or tap. Many people buy beautiful looking showers that give wonderful results with the minimum of pressure, but many customers are sold 'lemons', and often this is not because they did not ask the right questions but because they were misled, wrongly directed, or just plain lied to.

PULSING WATER AND TEMPERATURE PROBLEMS

This is an uncommon issue to have and it is due to issues in your plumbing system when you add a pump. The most common cause is back pressure so that's the first thing to check.

Before doing any tests, fully read this advice.

Remove the shower head as this reduces the back pressure. If it stops pulsing then a WRightChoice shower head may be all you need. You can buy WRightChoice shower heads on this site:-

<https://www.showerheadhosesmixers.co.uk/>

If it is not the shower head it could be the shower mixer but it could be air in the pipes. Removing the shower head will have increased the flow in the pipes, which may flush the air out. Refit the old shower head, and if the pulsing has gone, then the job's done.

Back pressure can also be caused by a poorly designed shower head, a shower hose with an internal bore less than 10mm, restrictions in the shower or tap mixer, air in the pipes, or some other blockage in the pipes.

MAXIMISE THE WATER FLOW TO CHECK IT ISN'T A CAPACITY PROBLEM

With the shower head removed and the pump running turn to full hot and measure the flow in litres a minute. Open other hot taps to the maximum, measure the flow at each tap and shower, and add the flow rates together. If you cannot get 8 litres a minute from multiple taps open at the same time then your problem is likely to be lack of water. The lack of water might be caused by:

1. Sediment in the bottom of a cold water tank
2. The valve between the cold water tank and the bottom of the hot water cylinder is corroded
3. The valve between the cold water tank and the bottom of the hot water cylinder is partly closed (turn anticlockwise to open)
4. There is scale in the bottom of your hot water cylinder
5. The top exit fittings at the top of the cylinder are corroded
6. Air in the pipework between the cold water tank and the bottom of the hot water cylinder, or in the pipework between the pump and shower. Increasing the water flow may flush out this air.

When water flowing though a hot water cylinder is limited, the vent pipe fills with water when the pump is not running. The pump can draw water from the vent pipe but pumps water away faster than it accumulates. The pump with no more water to pump causes the rotor to spin in a water/air mix which is so inefficient that the water builds up again and then, when there is enough water, it pumps efficiently again, but soon runs out of water again. The noise of the pump ramps up and down in pitch: pumping water is low pitch, pumping a water and air mix is a high pitch. To see and hear what a SPB starved of water sounds like visit this blog:
<https://showerpowerbooster.co.uk/blog/shower-power-booster-starved-of-water/>

PUMPS NOT TURNING OFF

Incorrect wiring is the most common reason for pumps not turning off. Please check the wiring diagrams in the fitting guide for your particular SPB.

If the blue light flashes rapidly - solid blue light - flashes rapidly, it tells you the problem is in the pipes or perhaps a hose pipe is expanding and contracting. With the pump running, maximise the flow to try to flush the air out by taking the shower head off, drop the shower head in the shower tray. Look for high points in the pipes which might trap air and fit barrel air valves. Fitting a 22mm single check valve (with reducers if necessary) on the pipe upstream of the SPB will stop this whatever the reason.

If the blue light flashes rapidly without a pause, it tells you the problem is water passing from the hot to the cold pipes or water passing from the cold to the hot pipes. Fitting a 22mm single check valve (with reducers if necessary) on the pipe upstream or downstream of the SPB will stop this water passing from the cold to the hot in the gravity hot mains cold systems. Fitting a SP2U on the cold to balance the hot pressure will stop hot water passing to the cold in gravity hot and cold systems.

EMAIL: SPB@flowflex.com

VISIT: www.showerpowerbooster.co.uk

PULSING WATER AND TEMPERATURE PROBLEMS

Check the hot water temperature

1.0 Many mixers have 'anti-scald' prevention which closes the hot port to the mixer if it senses very hot water. The anti-scald can be over-sensitive to hot water, or not-so-hot water, and overcorrects by closing the hot port too much. In response to closing the the hot port too much, the water becomes too cold and so opens the hot port again, but overcorrects and the cycle repeats.

2.0 Lowering the temperature to say 55 degrees or even 50 degrees may stop the anti-scald needing to react, but it might be that the mixer anti-scald is faulty.

3.0 Changing the temperature changes the water mix ratio, and the lower the temperature the higher the hot flow, and as a result the lower the hot pressure. The higher the temperature the lower the hot flow and so the higher the pressure. Changing temperature up or down will affect the dynamics and could give a sweet point which stops the pulsing.

Pulsing water or temperatures caused by a mixer

Mixers are less likely to pulse if you boost both the hot and cold, and for most a single pump on the hot gives a good shower and the mixer does not pulse.

Many mixers which pulse at one temperature and pressure are fine if you change the temperature of the incoming water. Turn the temperature of the hot water cylinder up and down. 20% of all mixers need balanced pressure on the hot and the cold, and if you just have a SP2B on the hot you need a SP2U upgrade pump on the cold.

Check the power supply

Check the socket and if necessary use an extension lead to bring power from another plug socket. This blog gives you an example of why this may be important <https://showerpowerbooster.co.uk/blog/pulsing-pumps/>

Problems with Thermostatic Taps and Shower Mixers

There are three reasons that a tap or shower mixer may be causing fluctuating flows and/or temperature fluctuation. These are oversensitivity, the cassette sticking, and/or restrictions in the tap which causes back pressure.

Thermostatic Mixers have a cassette which may be oversensitive or sticking.

A thermostatic mixer will try to balance hot and cold and will restrict the flow from the hot and the cold. When a mixer has not reached the temperature it wants, it will prioritise the hot port until hot water arrives. Once hot water arrives at the mixer it will reduce the flow from the hot port and increase the flow from the cold port to try to give the temperature you need. If the cassette is slow to act it may overcompensate and open the cold port too much and close down the hot too much, resulting in fluctuating temperature and pressure. There is often little you can do if its a faulty mixer. I have a guide to best shower mixers:-

<https://showerpowerbooster.co.uk/information/best-mixer-showers/>

RADIATOR FLOW BOOSTER

A Radiator Flow Booster can drive water to or from a radiator or a group of radiators which are not getting hot. In many homes radiators do not get hot due to air locks, poor pipework, or due to being located some distance from the boiler. You can install the pump on the flow to the radiator(s).

Version 1 (V1) is based on an original SPB and fits 22mm and 15mm pipes.
Version 2 (V2) is 15mm and fits directly to the radiator.

Diagram 41.1 Shows a V1 Radiator Flow Booster boosting a single radiator

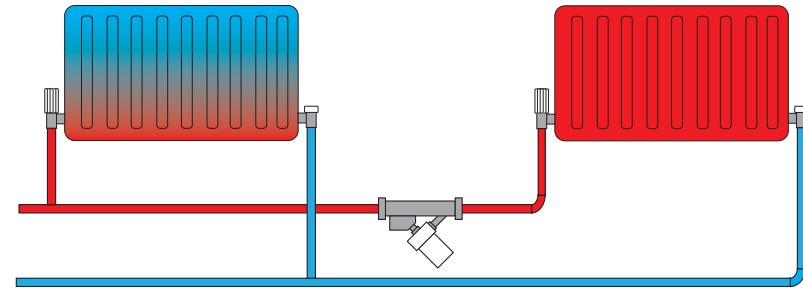

BALANCED SYSTEMS

A typical system is 'balanced' by adjusting the valves on each radiator to get all the radiators equally hot. The thermostatic valve on each individual radiator then reduces the flow to each radiator in response to the room temperature.

Diagram 41.2

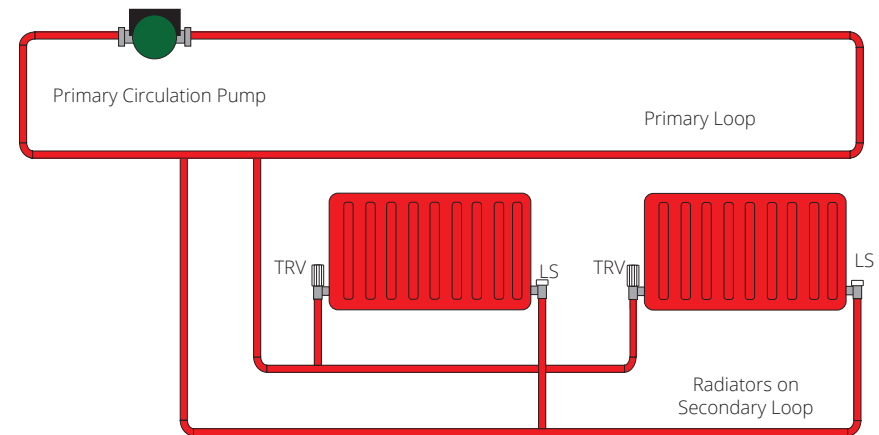

COLD RADIATORS

In homes there are often many sub loops and despite turning down the hottest radiators the flow avoids a loop with hydraulic resistance.

Diagram 42.1

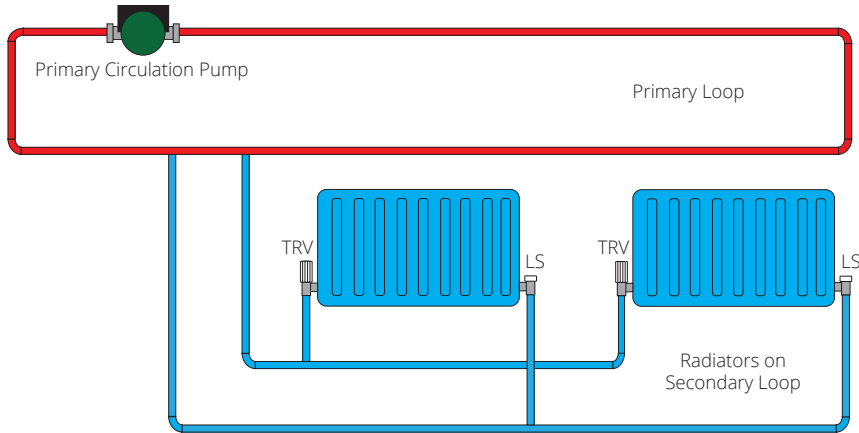

FITTING A RADIATOR FLOW BOOSTER

A WrightChoice Radiator Flow Booster fitted anywhere on the delivery creates a positive flow through any radiators on the secondary loop.

A V1 Radiator Booster can be fitted anywhere on the flow and hidden from sight.

A V2 Radiator Booster can be fitted in place of the Lockshield Valve (LS).

Diagram 42.2

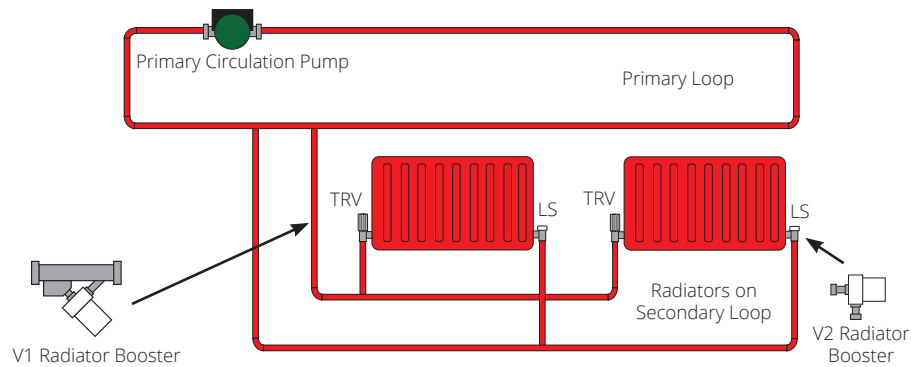

FITTING A V2 RADIATOR BOOSTER

The V2 Radiator Booster comes pre-assembled and tested. It replaces the Lock Shield Valve on a traditional radiator. It can be used to push water through the radiator or pull water from the radiator.

PLEASE SEE THIS VIDEO BEFORE YOU FIT YOUR V2 RADIATOR BOOSTER:

<https://www.youtube.com/watch?v=t7VMzSSkplM>

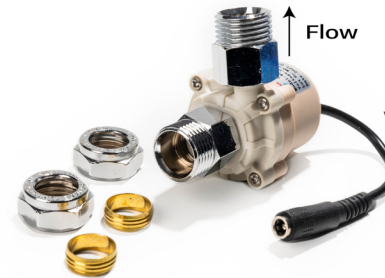

V2 Radiator Flow Booster showing flow direction.

The dimensions of the V2 radiator booster and the lock shield valve are not identical but in most cases you can connect the V2 Radiator Booster directly to the existing radiator tail. Fitting a new radiator tail can give further adjustment if needed.



We supply a radiator tail with all purchases and to achieve greater dimensional equivalence we have reduced the spigot length. The old tail screws out anticlockwise and the new tail screws in clockwise.

Use plenty of PTFE tape.



For more than 60 years Flowflex has been at the forefront of designing and engineering solutions for the heating and plumbing sector, delivering innovation and technical know-how to support contractors, consultants, installers and our distribution partners.

As a family business we pride ourselves in the integrity, quality and reliability we deliver through our products and people. With a strong heritage in British engineering and manufacturing we champion innovation and help to bring new and exciting solutions to the market.

Our vision is to be a world leader in engineering and manufacturing solutions for the heating and plumbing sector and beyond, including working in partnership with manufacturers across a variety of industries through our OEM solutions.



British Manufacturing and Engineering

Maintaining the highest quality in design, engineering and manufacture is a vital factor in the delivery of our fittings, valves and components. Operating on a six-acre site in the North of England, we ensure that we manufacture to the highest standards to produce outstanding products that are fit for purpose.

Over sixty years we have built the knowledge and expertise to develop superior engineering solutions for our customers and manufacture some of the most highly regarded non-ferrous plumbing fittings available on the market.

Our dedication and commitment to excellence in everything we do is evident in the loyalty of our customers and the reputation of our products.

www.flowflex.com



SP22S



SP2B



SP21S



ShowerPowerBooster

Suitable for all high and low pressure plumbing systems.

A pump that gives the same results as pumps 20 times bigger.

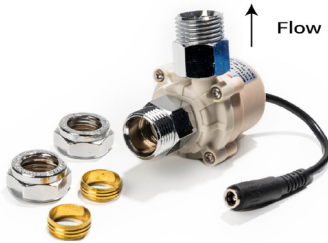

Radiator Flow Booster

Suitable for all central heating systems.

The only retrofit solution for lazy radiators.



Our **Energy Storage Device** has an amazing effect

Retrofitted to any standard cylinder it transforms it into a Thermal Store Cylinder.

RENEWABLE TECHNOLOGIES

I have developed multiple technologies in my own home which demonstrate that private individuals can benefit themselves and society in general with innovative technologies.

We have sold thousands of micro pumps to solve pressure problems (without the need to spend thousands of pounds on traditional solutions), that give the same results as pumps 20 times bigger. We solve problems in central heating systems that no other product can solve.

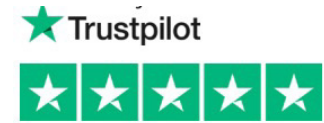

We are interested in forging relationships and selling throughout Europe and Worldwide. We can supply finished products B2B (business to business), or grant manufacturing and/or selling rights in your own country. Please contact Alan Wright.

Technologies in my home include:

- 8 M2 of solar panels with an amazing and novel micro pump driven solar thermal operating system.
- 32 M2 of photo voltaic solar panels.
- 5.5 KW Wood Burner (Scrap wood offcuts).
- 13.5 KW/Hr Tesla PowerWall.
- 500 litre (29 KW/Hr heat store), hot water cylinder with micropumps to link Solar Thermal, Solar Photovoltaic, Wood Burner, Gas Boiler, and Tesla battery store for optimum heat storage.
- 4,500 litres of stored rain water delivered at high pressure using micropumps.



THE INVENTOR | ALAN WRIGHT

The Shower Power Booster was invented by Chartered Civil Engineer and hydraulics expert Alan Wright, who has worked in municipal water for 30 years, 25 of which were at Anglian Water. Over the years Alan has designed and worked on many water projects and his expertise is often sought to provide solutions to complex problems.

In his early years, as a reservoir inspector, Alan was impressed by the superb work of Victorian engineers who understood the physics of water and made things happen without complex electronics. He discovered that the Victorians simply allowed the water to do what it wanted to do and not force it to do something it does not want to do! It is the mix of physics and simplicity which Alan has applied to his invention - the Shower Power Booster.

A result of careful and correct application of science, the Shower Power Booster uses innovative and unique patented technology which can transform your showering experience or enhance a dribbly tap, giving the same effect felt from a pump 20 times bigger.



@WrightChoiceSPB



@showerpressure



@showerpowerbooster



alandwright2

For assistance please contact product experts at Flowflex who will be able to offer advice and help you with any issues you may have.

PHONE: +44 (0) 1298 77211

EMAIL: SPB@flowflex.com

FLOWFLEX OFFICE HOURS:

Monday to Thursday 09:00 to 17:00

Friday 09:00 to 16:00

Alternative & Out Of Hours contact details are displayed on our website:

www.showerpowerbooster.co.uk